

*Made in Holland*

**PITT**  
COOKING

# ***Installation and handling instructions***

PITT Cooking in kitchen worktops  
**Induction**

---

These documents contain instructions to securely and successfully install a PITT Cooking gas cooking appliance into kitchen worktops. Furthermore, they indicate which level of craftsmanship is required. To make a warranty claim, installation procedures should be applied as described.  
PITT Cooking is exclusively intended for consumer use.

## Kitchen worktop: materials and dimensions

### Induction

	< 8 mm	10 - 35 mm
Granite	—	✓
Quartz/composite	—	✓
FENIX®	—	✓
Stainless steel and other conductive materials	✗	—
Ceramics/porcelain	✓	✓
Marble	—	✓
Natural stone <sup>1</sup>	—	✓
Terrazzo	—	✓
Glass	—	✓
Concrete	—	✓
Compact board	✗	✓
Non-homogeneous material (e.g. Travertine)	✗	✗
Solid Surface	✗	✗
Solid wood or with an HPL top layer	✗	✗

<sup>1</sup> = natural stone is a sensitive material because it is a product of nature. This means that each countertop is unique and can vary in strength, texture and durability. The composition of the stone can vary, making it more susceptible to scratches, stains or fractures.

— = not applicable

✗ = not approved

✓ = recommended

#### Worktop thickness

The minimum thickness of the **core material** is **4 mm**.

For **Top Side and Front Side** the maximum thickness for all materials is **35 mm**.

**This is only applicable for induction, see the gas document for the different maximum thicknesses.**

#### Worktop depth

- For all **Top Side models**, a minimum worktop depth of **600 mm** is required.
- For all **Front Side models**, a minimum worktop depth of **650 mm** is required.

#### Worktop specifications

The bottom of the core material needs to be completely flat whereby the countertop material must be completely **homogeneous**. Make sure to strictly follow the countertop manufacturer's instructions.

## Top Side

**Disclaimer:** the hole pattern shown below is for indication purposes only and may vary depending on the model.

For the entire kitchen design, carefully follow the processing instructions and manuals of PITT Cooking. This also applies to the instructions and manuals of any other manufacturers involved.

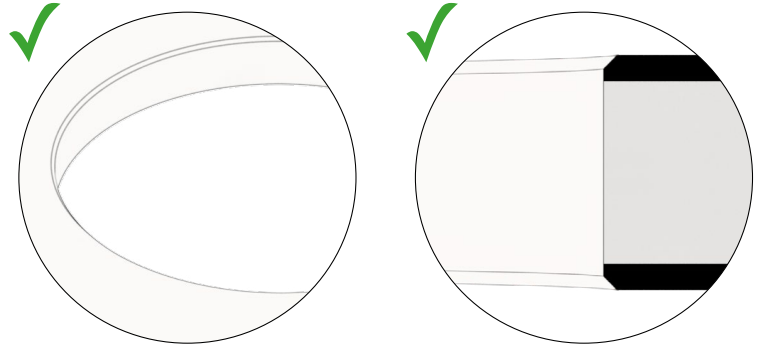

Apply a minimum chamfer of 1 x 1 mm to the **top** and **bottom** edges of the cutout.

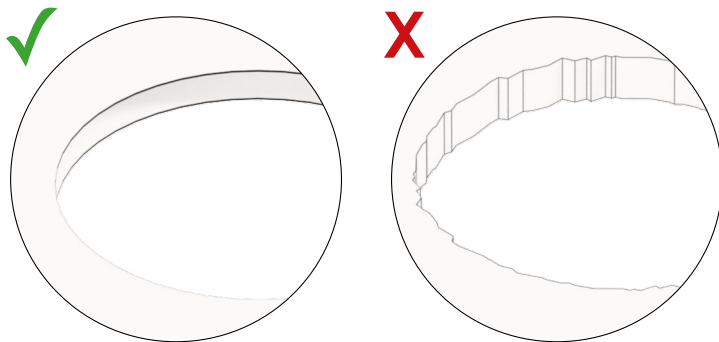
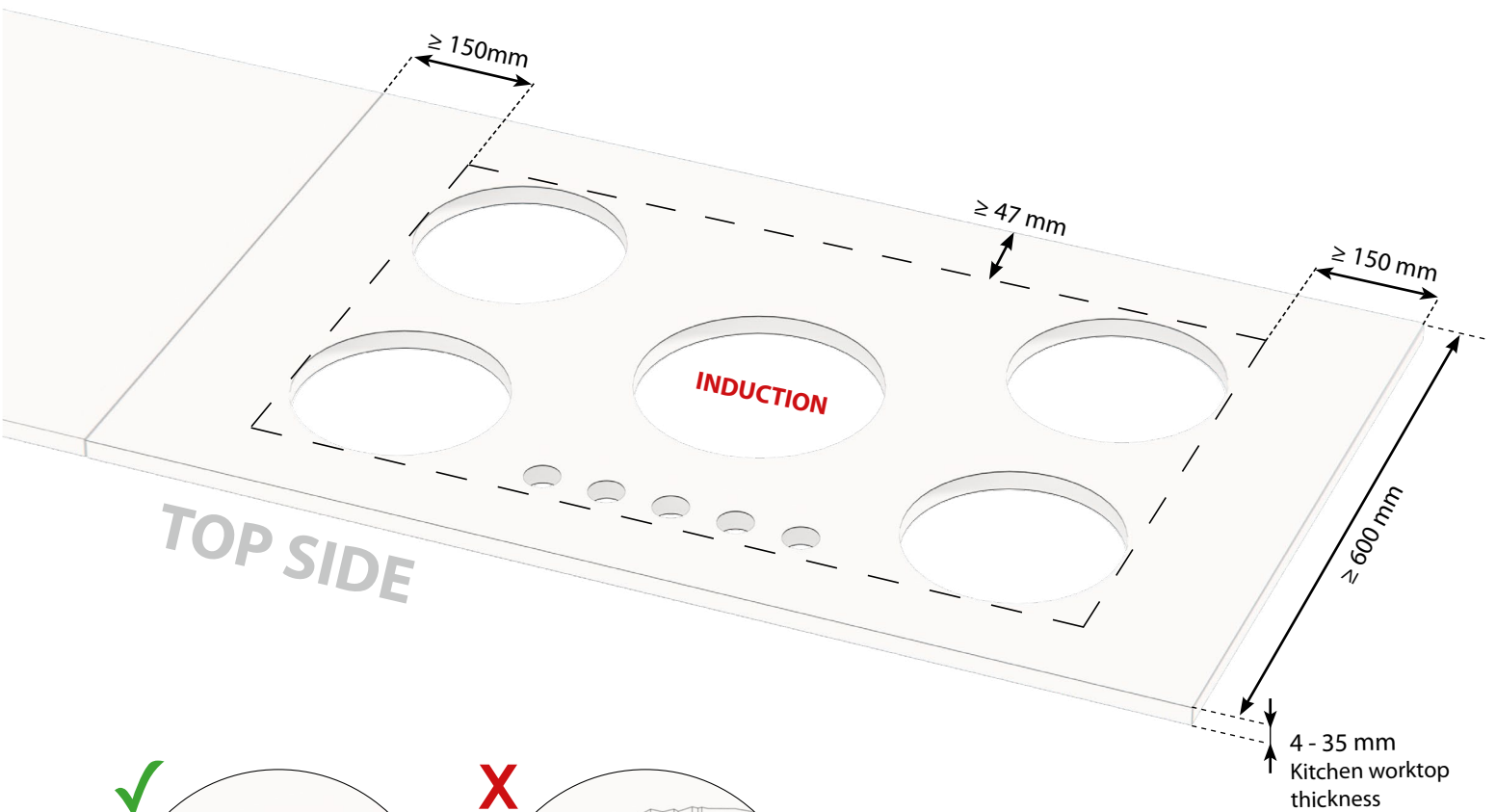

The inside of the cutout(s) must be smooth. Irregularities can cause cracking.

Technische tekening  
op de website verwijzing  
Diameter van kleine en grote zone  
laten zien

## Front Side

**Disclaimer:** the hole pattern shown below is for indication purposes only and may vary depending on the model.

For the entire kitchen design, carefully follow the processing instructions and manuals of PITT Cooking. This also applies to the instructions and manuals of any other manufacturers involved.

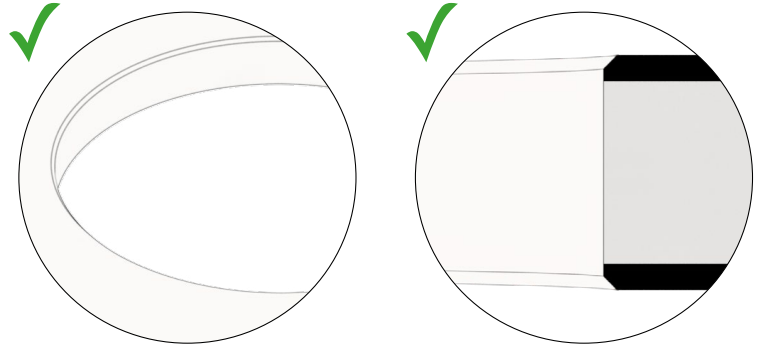

Apply a minimum chamfer of 1 x 1 mm to the **top and bottom** edges of the cutout.

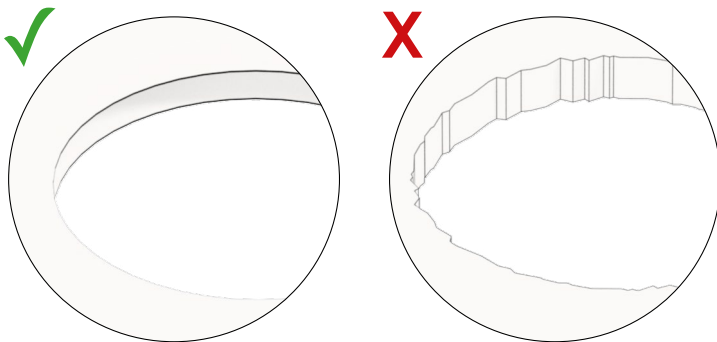
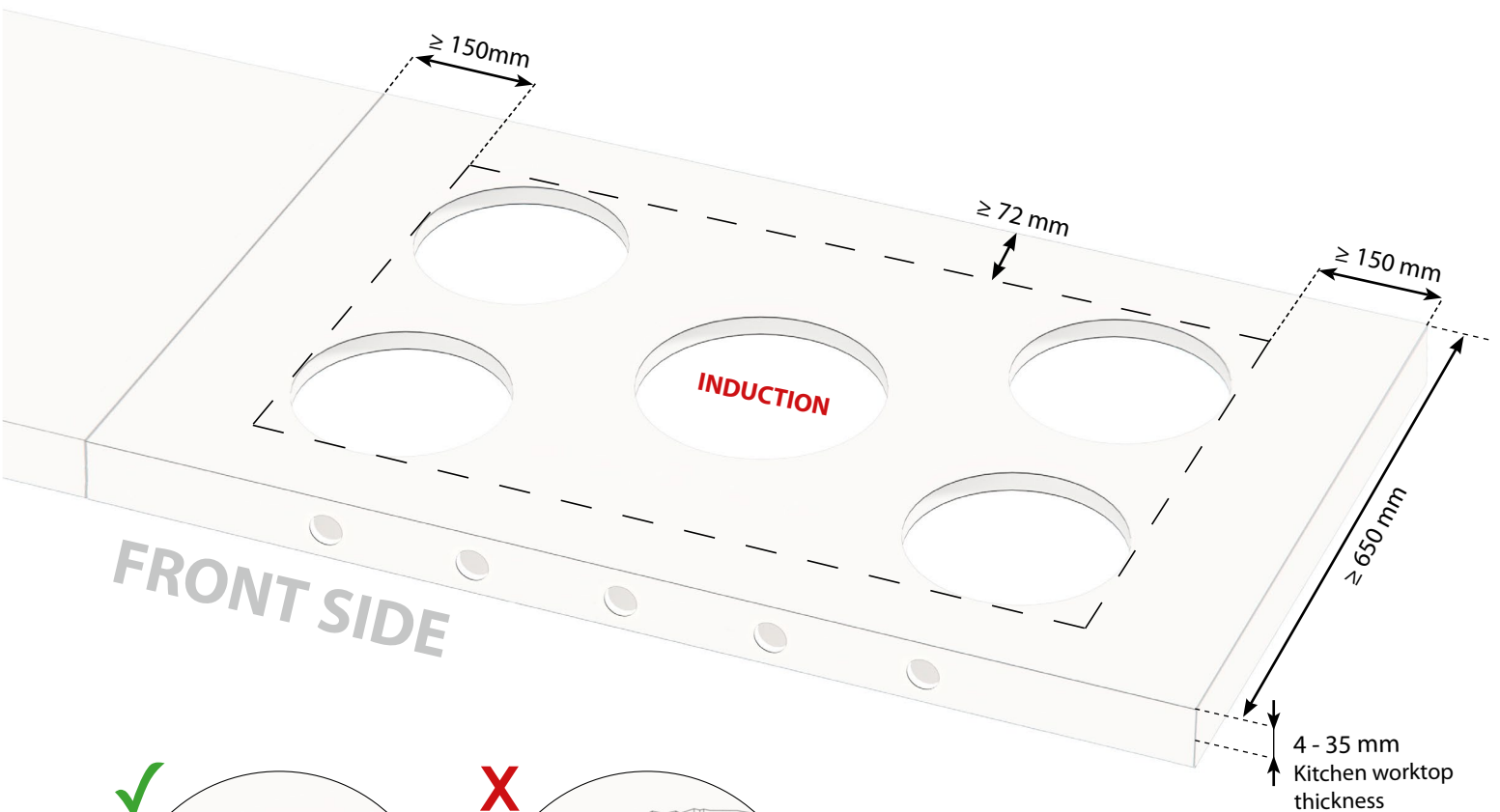

The inside of the cutout(s) must be smooth. Irregularities can cause cracking.

## Installation and processing instructions

Ensure that the worktop is **fully supported on the front, back, left, and right sides** of the PITT Cooking module. This prevents stress in the worktop caused by the weight of the PITT Cooking module. It is also important that the kitchen cabinets are completely stable and level so that the worktop lies flat as well.

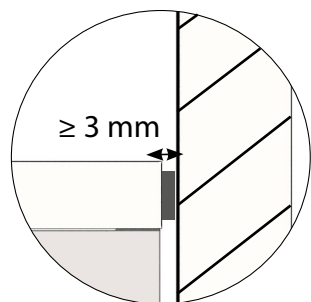

### Worktop expansion

The gap between the worktop and the wall and/or the gap between the two worktops must be at least 3 mm. This allows the material to expand.

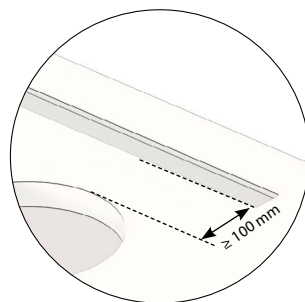

### Integrated ventilation

Ensure that the distance between the holes in the worktop is  $\geq 100$  mm. To avoid stress, the ventilation cannot be supported by the worktop.

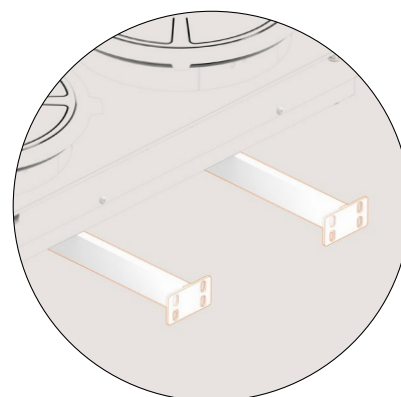
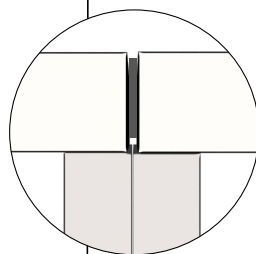

### Support set

It is mandatory to support the PITT Cooking device with the supplied support set. See the installation manual.

**Ventilation**  
Provide sufficient ventilation at the front and rear of the kitchen cabinet so that heat can escape.

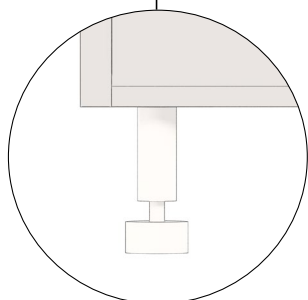

### Kitchen cabinet and leveling feet

Ensure the kitchen cabinets are completely level. The leveling feet must rest firmly on the floor.

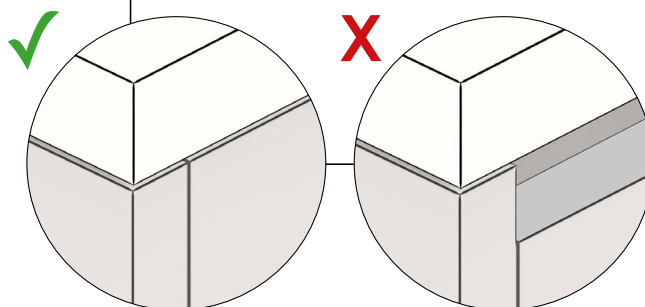

### Worktop support

Make sure the worktop is evenly supported across the cabinet carcass.

## Installation and processing instructions

### Thickened worktops

For thickened worktops, it is mandatory to construct a (ladder) frame so that the worktop is supported all around (front, back, left, and right sides) by the cabinet carcass. The worktop must be glued in such a way that the worktop and the reinforcement function as a single unit.

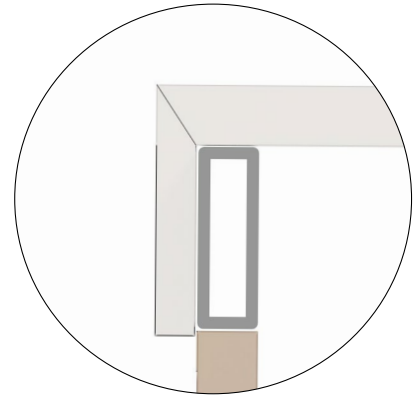

Reinforcements must be aligned with the load-bearing structure of the kitchen cabinet, as illustrated above.

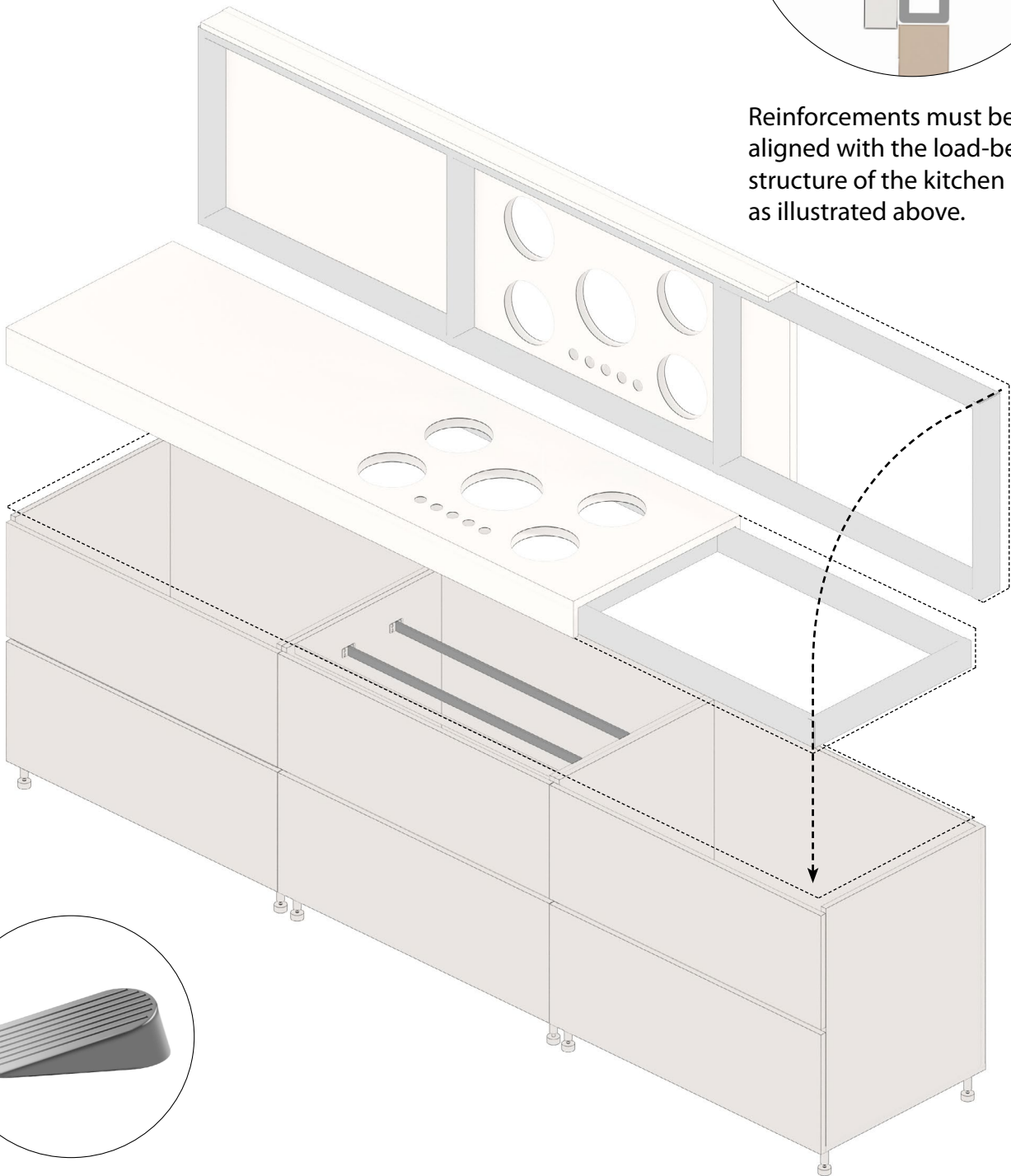

### The wedges

The use of wedges is **strictly prohibited**. This applies to all types of worktops.